

Maths Revision



Number and Place Value

Use numbers from -1000 to 10 000 000

Counting

Count forwards and backwards in 4, 6, 7, 8, 9, 25, 50, steps of powers of 10 (10, 100, 1000,...)

1a) Continue the sequence by increasing each number by 25:

150, _____, _____, 225, _____, _____, _____

b) Continue the sequence by decreasing each number by 100:

_____, 830, _____, _____, 530, _____, _____

c) Continue the sequence by increasing each number in powers of 1000:

11 345, _____, _____, _____, _____, _____

Find 10, 100 or 1000 more or less than a given number.

2a) What is 100 less than 1902?

b) What is 1000 more than 3249?

c) Count forwards and backwards through zero:

3, _____, _____, _____, -1, _____, _____, _____

Negative numbers

Use negative numbers in context and calculate intervals across zero.

3) The temperature inside is 19°C and outside is -4°C . What is the difference in temperature between inside and outside?

Place Value

Recognise the place value of each digit in up to four-digit numbers.

4a) Underline the hundreds digit in the following numbers:

7845

689

2038

b) Underline the tens digit in the following numbers:

776

3890

1428

Compare and Order Numbers

Compare using $<$, $>$ or $=$

5a) 141 141 144 114 501 243 501 234

b) Organise the following from smallest to largest:

122 211 11 211 11 112 121 211 122 121

Smallest _____ Largest

Identify, Represent and Estimate

Use models and representations of numbers.

6) Represent 2850 by colouring in the correct number of dienes:

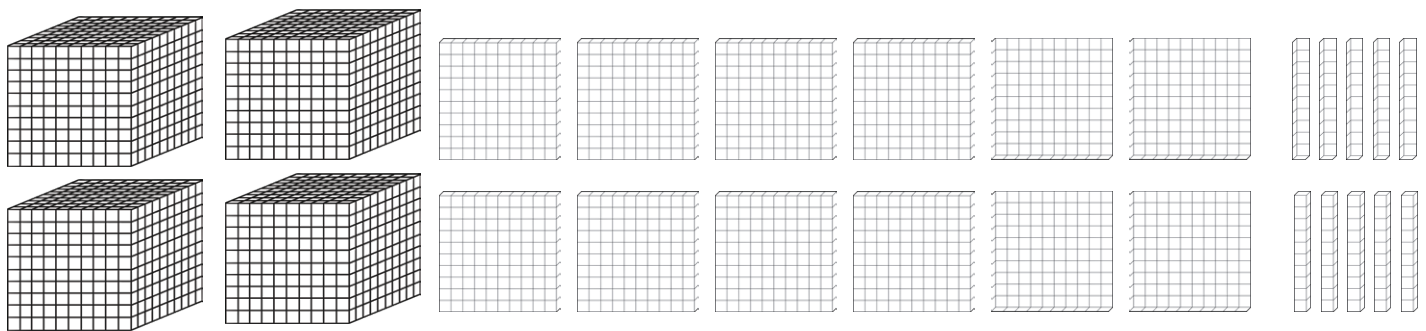

Rounding

Round numbers to the nearest 10, 100, 1000, 10 000 or 100 000 and any whole number.

(Remember 5 rounds up!)

8a) 4500 rounded to the nearest _____ is 5000 (the ____ rounds up).

b) 253 450 to the nearest 10 000 is _____ (the ____ rounds down).

c) 374 rounded to the nearest 50 is _____ (74 is nearer to ____ than ____).

Read and Write Numbers in Numerals and Words

9) 344 285 in words is _____.

Roman Numerals

10a) Fill in the table to show what each Roman numeral represents:

Roman	Numeral

b) CMXLVIII = 948

CCXIX = _____

626 = _____

MDCCLXXI = _____

Solve Problems

c) Here are 3 years written in Roman Numerals. Order the years from earliest to latest:

MMIX, MCMXCIX, MMXV

Addition and Subtraction

Add and Subtract Mentally

Add and subtract three-digit numbers and ones, tens and hundreds.

1a) $376 + 3 = \underline{\quad}$ b) $376 + 40 = \underline{\quad}$ c) $376 + 200 = \underline{\quad}$

Mental Methods

Add and subtract numbers mentally with larger numbers.

2) $15\,672 - 3200 = \underline{\quad}$

Estimate, Round, Levels of Accuracy and Inverse

Estimate by rounding to check accuracy:

3a) $54318 + 21298 \approx \underline{\quad} + \underline{\quad} \approx 75600$

b) Inverse: check $7932 - 3457 = 4475$, by $\underline{\quad} + \underline{\quad} = \underline{\quad}$

Multiplication Tables

Multiplication and division facts to 12×12 .

4) Fill in the missing numbers:

x	1	2	3	4	5	6	7	8	9	10	11	12
1	1	2		4	5	6		8	9	10	11	12
2	2	4	6		10	12		16	18		22	24
3		6	9	12	15		21	24	27			36
4	4	8	12	16	20	24		32	36	40	44	48
5	5		15	20		30	35	40	45	50	55	65
6	6	12		24	30	36		48	54	60		72
7			21			42		56		70	77	84
8	8	16	24		40		56	64	72			96
9	9		27	36	45	54		72	81	90		108
10	10	20		40		60	70			100	110	120
11		22	33	44	55	66		88	99			
12	12	24	36	48	60	72	84	96	108	120	132	144

Multiplying and Dividing

5a) Use place value and known facts: $400 \times 5 = \underline{\hspace{2cm}}$, $630 \div 7 = \underline{\hspace{2cm}}$

Multiply by 0 and 1 and divide by 1: $285 \times 1 = \underline{\hspace{2cm}}$, $285 \times 0 = \underline{\hspace{2cm}}$, $285 \div 1 = \underline{\hspace{2cm}}$.

b) When multiplying the number gets and when dividing the number gets .

c) The numbers will move in place value by the number of 0s.

$$45 \times 10 = \underline{\hspace{2cm}} \qquad 6.7 \times 100 = \underline{\hspace{2cm}} \qquad 902 \times 1000 = \underline{\hspace{2cm}}$$

$$59 \div 10 = \underline{\hspace{2cm}} \qquad 4506 \div 100 = \underline{\hspace{2cm}} \qquad 382 \div 1000 = \underline{\hspace{2cm}}$$

Common Multiples, Factor Pairs, Common Factors and Commutativity

6a) 12 is a common multiple of and , because 12 is a multiple of and a multiple of .

All the factor pairs of 56 are and , and , and , and .

Use this to solve:

b) 56 pencils are shared between 4 tables. How many pencils does each table receive? .

c) The common factors of 32 and 56 are , , and because they are factors of both 32 and 56.

d) Commutativity means changing the order of the numbers in a calculation but the answer does not change. What other two ways can this calculation be written so that it gives the same answer? $5 \times 9 \times 2 = \underline{\hspace{1cm}} \times \underline{\hspace{1cm}} \times \underline{\hspace{1cm}} = \underline{\hspace{1cm}} \times \underline{\hspace{1cm}} \times \underline{\hspace{1cm}} = \underline{\hspace{1cm}}$

Prime Numbers

7a) Prime numbers only have 1 and as factors.

b) Prime factors are factors of a number that are :

c) The prime factors of 21 are and .

d) The prime factors of 24 are and .

Composite numbers are non-prime numbers: 4 is a composite number because 2 is a factor.

e) Recall the prime numbers to 19: .

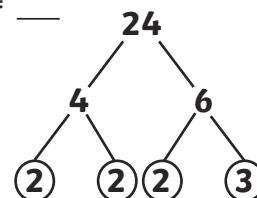

Square and Cube Numbers

8a) The square numbers are 1, _____, 225...

e.g. $___{}^2 = ___ \times ___ = 9$ $___{}^2 = ___ \times ___ = 49$

b) The cube numbers are 1, _____, _____, _____, 125,...

e.g. $___{}^3 = ___ \times ___ \times ___ = 8$ $___{}^3 = ___ \times ___ \times ___ = 125$

e.g. $2^3 = 2 \times 2 \times 2 = 8$ $5^3 = 5 \times 5 \times 5 = 125$

Order of Operations

BODMAS is a way of remembering the order in which operations are carried out.

9a) Brackets first: $3 \times (4 + 5) = ___ \times ___ = ______$

b) Order - square or cube: $4 + 3^2 = ___ + ___ = ______$

c) Division and Multiplication: $4 + 3 \times 2 = ___ + ___ = ______$

Addition and Subtraction: (as in examples above)

Division and multiplication are carried out in the order they are in the expression.

Addition and subtraction are carried out in the order they are in the expression.

Formal Methods

Use a written method to solve the following addition and subtraction calculations:

10a) $72\ 698 + 61\ 562$

b) $84\ 935 - 12\ 423$

c) $64\ 812 - 29\ 364$

Use a written method to multiply up to 4-digit numbers by 1-digit numbers.

d) 27×4

e) 382×7

f) 2471×6

Use a written method to multiply 2-digit numbers by 2-digit numbers.

g) 27×14

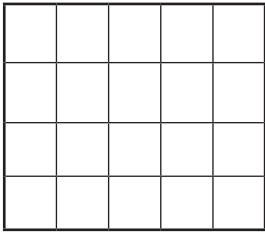

h) 14×23

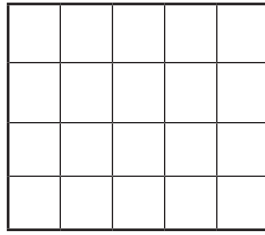

Use short division for up to 4 digit numbers divided by one-digit numbers.

i) $76 \div 4$

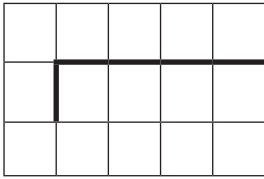

j) $487 \div 5$

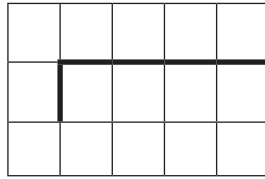

Use long division for up to 4 digit numbers divided by two-digit numbers.
Express remainders as whole numbers, fractions or decimals.

k) $516 \div 15$

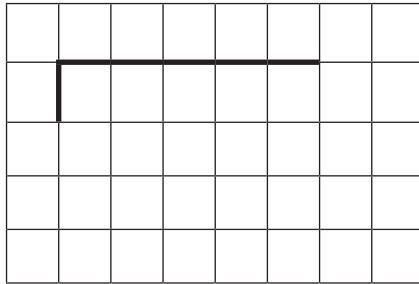

Solve Problems

Multi-step problems

11) 8451 people visit a cinema on one day. There are two films showing. 3549 adults and 946 children see an adventure film, 1263 adults and a number of children see an animation. How many more children see the animation than the adventure film?

a) $3549 + 1263 =$ _____ adults

b) $8451 - 4812 =$ _____ children

c) $3639 - 946 =$ _____ children see the animation

d) $2693 - 946 =$ _____ more children see the animation than the adventure film

12a) Write the following numbers in each Venn Diagram:

2, 8, 5, 10, 3, 1, 9, 4, 6, 7

Prime Numbers

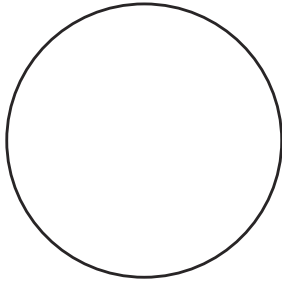

Square Numbers Composite Numbers

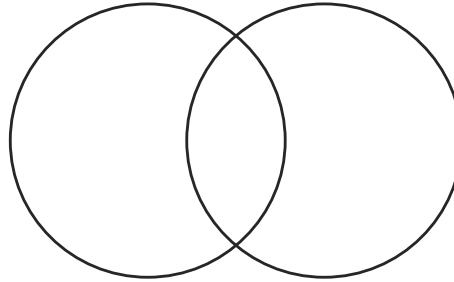

b) Explain why a prime number will never be a square number.

c) Fill in the missing numbers:

$$\square \times 3 = 45 \quad \text{or} \quad 56 \div \square = 14$$

Word Problems

A teacher has four new boxes of pencils, each with 12 pencils, and a tray with 37 pencils. The teacher shares equally all the pencils between 5 tables. How many pencils does each table receive?

13a) $12 \times 4 =$ _____ new pencils

b) $48 + 37 =$ _____ pencils

c) $85 \div 5 =$ _____ pencils per table

Solving Problems with Simple Fractions

14) 12 pizzas are cut into quarters. How many quarters of pizza will there be altogether? _____.

Correspondence Problems

15) Jenna has 2 t-shirts and 4 pairs of shorts. How many possible combinations of t-shirts and shorts does Jenna have? _____.

Using the Distributive Law

16) Multiplying a number by distributing it into a group of numbers added together.
For example:

$$39 \times 7 = \underline{\quad} \times 7 + \underline{\quad} \times 7 = 210 + 63 = \underline{\quad}.$$

Fractions

Tenths

1) Colour in the bar to show what fraction comes next in the sequence:

$$\frac{7}{10}, \frac{6}{10}, \frac{5}{10}, \frac{4}{10}, \dots$$

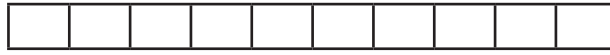

Hundredths

2) Colour in the grid to show what fraction comes next in the sequence:

$$\frac{47}{100}, \frac{46}{100}, \frac{45}{100}, \frac{44}{100}, \dots$$

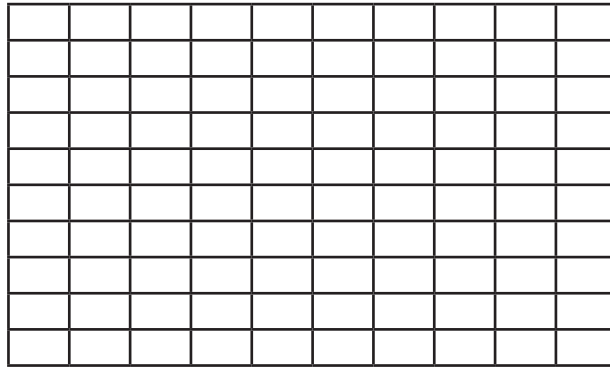

Fraction of a Set of Marbles

3) Colour in $\frac{5}{8}$ of these marbles:

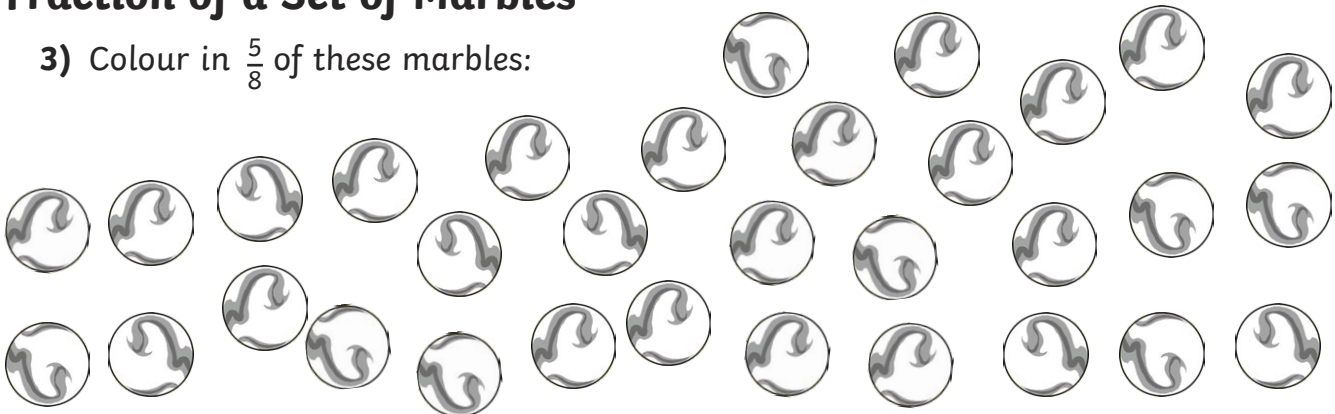

$$32 \div 8 = \square$$

$$4 \times 5 = \square$$

Equivalent Fractions

4a) Colour in the bars to represent the equivalent fractions:



$$\frac{3}{4}$$

=

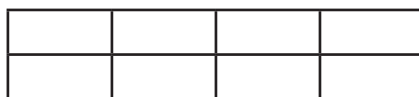

$$\frac{6}{8}$$

=



$$\frac{12}{16}$$

1							
$\frac{1}{2}$				$\frac{1}{2}$			
$\frac{1}{4}$		$\frac{1}{4}$		$\frac{1}{4}$		$\frac{1}{4}$	
$\frac{1}{8}$	$\frac{1}{8}$	$\frac{1}{8}$	$\frac{1}{8}$	$\frac{1}{8}$	$\frac{1}{8}$	$\frac{1}{8}$	$\frac{1}{8}$

1																				
$\frac{1}{3}$				$\frac{1}{3}$				$\frac{1}{3}$												
$\frac{1}{6}$			$\frac{1}{6}$			$\frac{1}{6}$			$\frac{1}{6}$											
$\frac{1}{12}$	$\frac{1}{12}$	$\frac{1}{12}$	$\frac{1}{12}$	$\frac{1}{12}$	$\frac{1}{12}$	$\frac{1}{12}$	$\frac{1}{12}$	$\frac{1}{12}$	$\frac{1}{12}$	$\frac{1}{12}$	$\frac{1}{12}$									
$\frac{1}{24}$	$\frac{1}{24}$	$\frac{1}{24}$	$\frac{1}{24}$	$\frac{1}{24}$	$\frac{1}{24}$	$\frac{1}{24}$	$\frac{1}{24}$	$\frac{1}{24}$	$\frac{1}{24}$	$\frac{1}{24}$	$\frac{1}{24}$	$\frac{1}{24}$	$\frac{1}{24}$	$\frac{1}{24}$	$\frac{1}{24}$	$\frac{1}{24}$	$\frac{1}{24}$	$\frac{1}{24}$	$\frac{1}{24}$	$\frac{1}{24}$

1																			
$\frac{1}{5}$					$\frac{1}{5}$					$\frac{1}{5}$					$\frac{1}{5}$				
$\frac{1}{10}$		$\frac{1}{10}$		$\frac{1}{10}$		$\frac{1}{10}$		$\frac{1}{10}$		$\frac{1}{10}$		$\frac{1}{10}$		$\frac{1}{10}$		$\frac{1}{10}$		$\frac{1}{10}$	
$\frac{1}{20}$	$\frac{1}{20}$	$\frac{1}{20}$	$\frac{1}{20}$	$\frac{1}{20}$	$\frac{1}{20}$	$\frac{1}{20}$	$\frac{1}{20}$	$\frac{1}{20}$	$\frac{1}{20}$	$\frac{1}{20}$	$\frac{1}{20}$	$\frac{1}{20}$	$\frac{1}{20}$	$\frac{1}{20}$	$\frac{1}{20}$	$\frac{1}{20}$	$\frac{1}{20}$	$\frac{1}{20}$	$\frac{1}{20}$

b) Write 4 fractions that are equivalent to $\frac{3}{4} = \underline{\quad} \underline{\quad} \underline{\quad} \underline{\quad}$

c) Use common factors to simplify fractions:

$\frac{9}{15} = \frac{3}{5}$ 9 and 15 have $\underline{\quad}$ as a common factor.

Expressing Fractions with the Same Denominator

5) Use common multiples

$\frac{4}{5}$ and $\frac{3}{8}$

$\underline{\quad}$ is the smallest common multiple of 5 and 8

$\frac{4}{5}$ becomes $\underline{\quad}$ $\frac{3}{8}$ becomes $\underline{\quad}$

Mixed Numbers and Improper Fractions

6a) Change this mixed number into an improper fraction:

$$1 \frac{2}{3} = \underline{\hspace{2cm}}$$

b) Change this improper fraction into a mixed number:

$$\frac{14}{3} = \underline{\hspace{2cm}}$$

Add and Subtract Fractions with the Same Denominator and with Denominators that are Multiples, and with Different Denominators and Mixed Numbers

7) Add or subtract the numerator, keeping the denominator the same. The answer can be expressed as an equivalent fraction. Fill in the missing numbers and colour in the bar to represent the fraction.

a) $\frac{1}{8} + \frac{3}{8} = \frac{\quad}{8} = \underline{\hspace{1cm}}$

--	--	--	--	--	--	--	--

b) $\frac{5}{8} - \frac{3}{8} = \frac{\quad}{8} = \underline{\hspace{1cm}}$

--	--	--	--	--	--	--	--

If the denominators are different, convert the fractions to equivalent fractions with the same denominator before adding or subtracting:

c) $\frac{1}{4} + \frac{3}{8} = \underline{\hspace{1cm}} + \underline{\hspace{1cm}} = \underline{\hspace{1cm}}$

d) $\frac{4}{5} + \frac{3}{8} = \underline{\hspace{1cm}} + \underline{\hspace{1cm}} = \underline{\hspace{1cm}} = \underline{\hspace{1cm}}$

Compare and Order

8a) Arrange these unit fractions from smallest to largest: $\frac{1}{3}$ $\frac{1}{6}$ $\frac{1}{4}$ $\frac{1}{8}$

smallest $\underline{\hspace{1cm}}$ $\underline{\hspace{1cm}}$ $\underline{\hspace{1cm}}$ $\underline{\hspace{1cm}}$ largest

b) Use $>$, $<$ or $=$ to compare these fractions:

$$\frac{1}{5} \square \frac{3}{5}$$

$$\frac{5}{8} \square \frac{1}{4}$$

Multiply Fractions

Multiply proper fractions and mixed numbers by whole numbers.

9a) Proper fractions: multiply the numerator by the whole number: $\frac{2}{3} \times 5 = \text{---} = 3 \text{---}$

b) Mixed numbers: multiply the whole numbers and add the product of the fraction and whole number: $2\frac{2}{3} \times 3 = \text{---} + \text{---} = \text{---} + \text{---} = \text{---}$

Divide Fractions

10) Divide proper fractions by whole numbers – multiply the denominator by the whole number:

$$\frac{1}{4} \div 2 = \text{---}$$

Decimal Equivalents

11a) Write the following fractions as decimals:

$$\frac{7}{10} = \text{---}$$

$$\frac{43}{100} = \text{---}$$

$$\frac{1}{4} = \text{---}$$

$$\frac{1}{2} = \text{---}$$

$$\frac{3}{4} = \text{---}$$

b) Write decimals as a fraction: $0.67 = \text{---}$

c) Calculate decimal fraction equivalents: $\frac{3}{8} = \text{---}$ because $3 \div 8 = \text{---}$

Decimal Place Value

Write the value of each digit in the number 0.492:

12a) $0.492 =$ zero ones + _____ + _____ + _____

Solve Problems

Fractions

Adil wants to share his savings with his friends. He has £120. He gives $\frac{1}{4}$ to his friend Tommy and $\frac{3}{10}$ to Barney.

17a) How much money will they both receive? _____

b) How much money will Adil be left with? _____

Measure and Money Problems

18a) Ellie buys a new shirt for £4.75 and a pair of trousers for £3.50 in a sale. She pays with a £10 note. What change will she receive?

b) A bag of potatoes weigh 2.45kg. How much will 4 bags weigh?

Decimal Problems to 3 Decimal Places

19a) A packet of sugar weighs 1.348kg. $\frac{3}{4}$ kg is used to bake some cakes.

How much will the packet weigh now?

Knowing Percentage and Decimal Equivalents of $\frac{1}{2}$, $\frac{1}{4}$, $\frac{1}{5}$, $\frac{2}{5}$, $\frac{4}{5}$, $\frac{*}{10}$, $\frac{*}{25}$

20) Order the following from smallest to largest:

25%, $\frac{2}{5}$, 0.3

Ratio and Proportion

Use Multiplication and Division Facts

- 1) 4 children share 6 pizzas. If 2 more children join the group and each child is to have the same amount of pizza, how many more pizzas are needed?
- _____

Percentages

- 2) Circle which is greater: 15% of 2 litres or 50% of 500ml

Scaled Shapes

- 3) The length and width of rectangle A are increased by a scale factor of 3 to make rectangle B. What are the new dimensions of rectangle B?

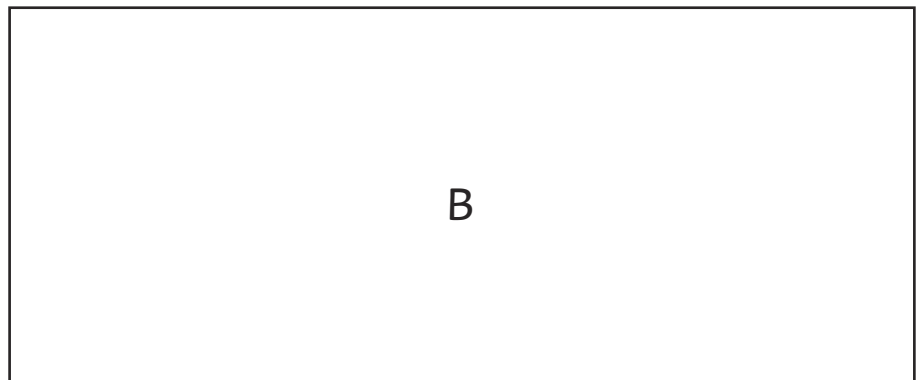
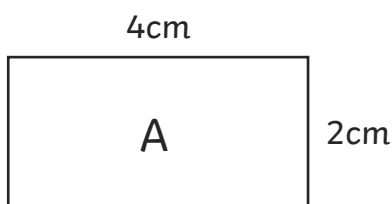

Use Fractions and Multiples

- 4) A child has read 50 pages of a book and has $\frac{3}{5}$ to read.
How many pages are there left to read?
- a) $\frac{2}{5}$ of the book has been read which is _____ pages
- b) $\frac{1}{5}$ of the book is _____ pages
- c) $\frac{3}{5}$ of the book is _____ pages. There are _____ pages left to read.

Algebra

Formulae

1a) $2s + 4 = t$, if $s = 5$, what is t ?

$$t = \underline{\quad} \times \underline{\quad} + \underline{\quad} = \underline{\quad}$$

Formulae are used in mathematics and science:

Area of a rectangle:

$a = lw$ (a = area, l = length and w = width)

Perimeter of a rectangle:

$p = 2(l + w)$ (p = perimeter)

b) What is the area and perimeter of this rectangle?

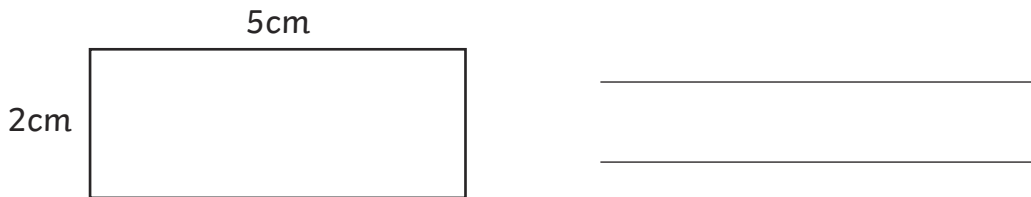

Express missing number problems algebraically:

2a) If a number (g) is 12 more than a number (h):

$$g = \underline{\quad} + \underline{\quad} \text{ or } h = \underline{\quad} - \underline{\quad}$$

a) A locksmith charges £15 callout and £20 per hour for any work. What formulae would calculate his charge for h number of hours?

_____.

Sequences

This linear sequence starts with 3 and each step is 4: 3, 7, 11, 15...

3) The 1st term is $4 \times 1 - 1 = 3$, the 2nd term is $4 \times 2 - 1 = 7$, the 3rd is $4 \times 3 - 1 = 11$...

therefore the n th term is _____.

Equations

4) Find possible pairs of numbers for a and b in $3a + b = 12$.

Variables

5) The total of two numbers is 15. Both numbers are between 5 and 10.

Find all the possible combinations.

Measurement

Estimate, Measure, Compare, Add and Subtract

Measure and draw lines using a ruler in centimetres (cm) or millimetres (mm).

Lengths (mm/cm/m)

1a) Measure this line in cm.



b) Draw a line that is 12.5mm long.

Mass (g/kg)

Measure the mass of objects using different scales.

4a) 3 apples weigh 435g. One is eaten, and the 2 remaining apples weigh 285g.

b) What is the mass of the eaten apple? _____

Capacity (ml/l)

5) Circle which jug has more water.

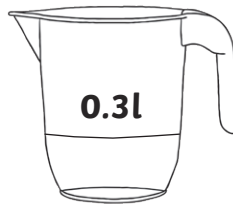

Convert between units

6a) Length: 1 km = _____ m, 1m = _____ cm or _____ mm, 1cm = _____ mm

b) Mass: 1kg = _____ g

c) Capacity/ Volume: 1l = _____ ml

d) Time: 1 year = _____ days

(leap year _____ days),

1 week = _____ days,

1 day = _____ hours,

1 hour = _____ minutes,

1 minute = _____ seconds.

e) _____ days hath September,
April, June and November.
All the rest have _____,
Excepting February alone
Which only has but _____ days clear
And _____ in each leap year.

Convert between metric and imperial units

7a) 1 inch \approx _____ cm 5 miles \approx _____ km
1 kg \approx _____ (pounds) 1 litre \approx _____ pints

b) A road sign says Sheffield 45 miles. How many kilometres is it to Sheffield? _____ km

Perimeter, Area and Volume

The perimeter is the measurement around the edge of a shape.



8a) The sides of this rectangle are 8cm and 3cm, so the perimeter is _____ cm.

b) Measure and calculate the perimeter of rectilinear shapes (including squares).

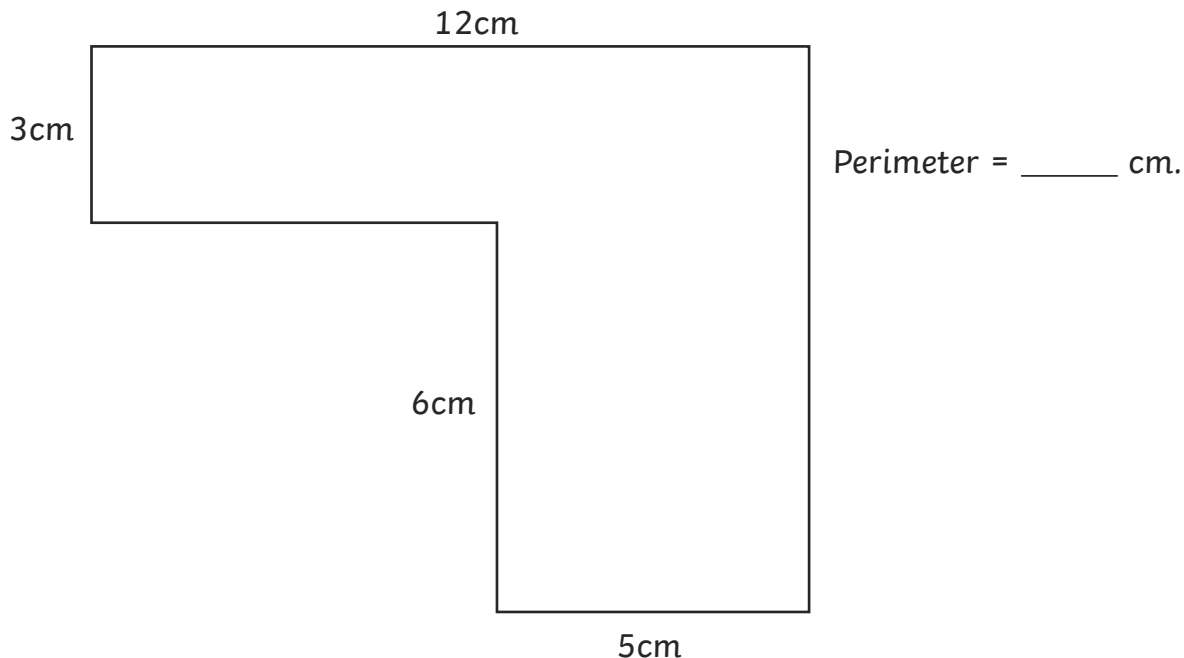

Area

9a) Find the area of rectilinear shapes by counting squares.

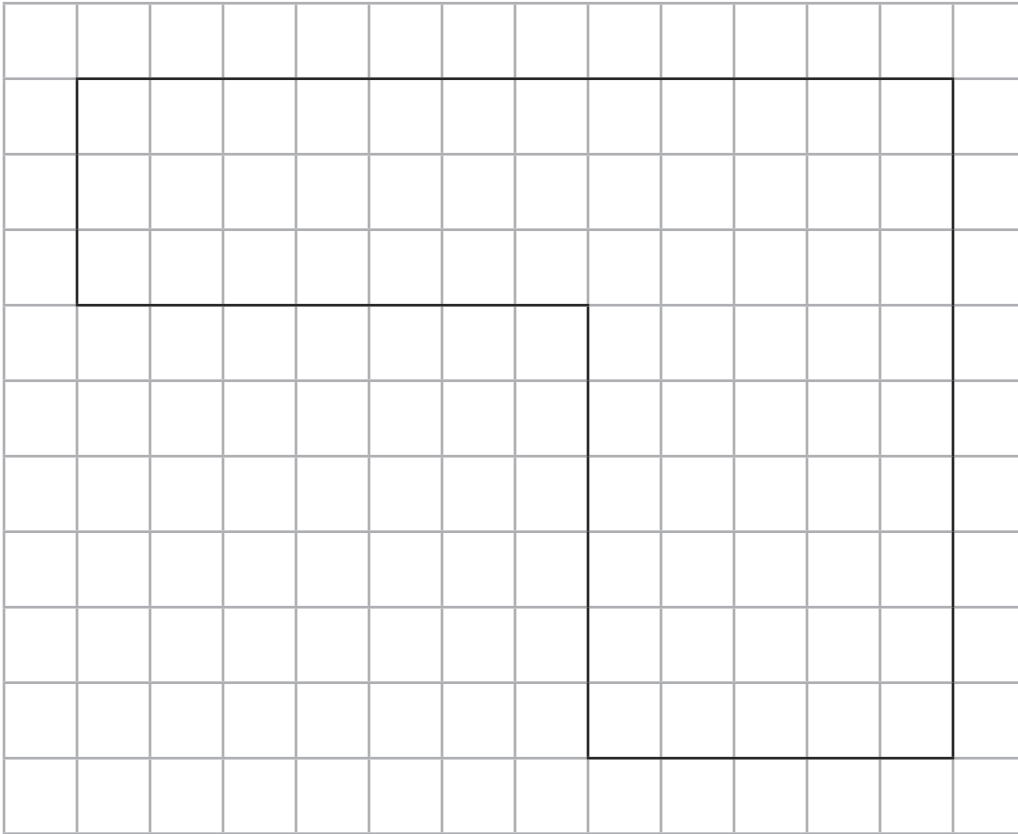

Area = _____ cm^2

b) Calculate the area of rectangles: multiply the length of two adjacent sides.



3cm Area = $8\text{cm} \times 3\text{cm} =$ _____ cm^2

8cm

c) Estimate the area of irregular shapes by counting the whole squares and the squares with more than half included in the shape:

1 square = 1cm^2

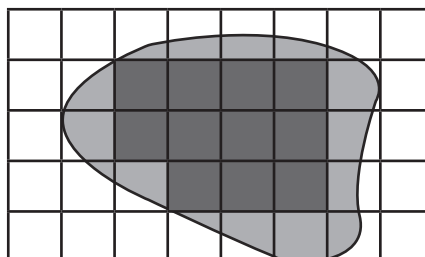

Area = _____ cm^2

Shapes with the same area can have different perimeters.

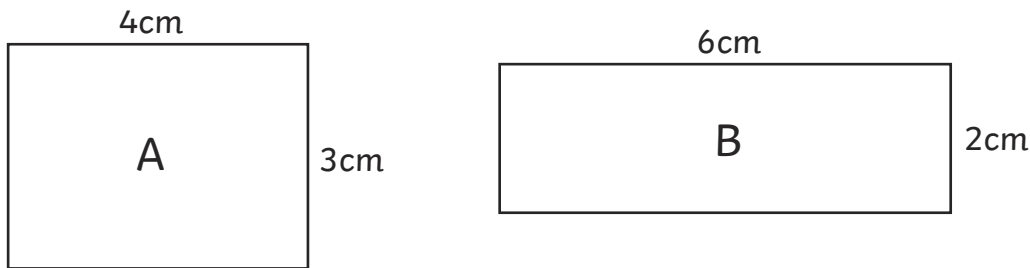

d) Find the area and perimeter of these rectangles. What do you notice?

The area of a triangle is based on it being half of a rectangle that includes the triangle.

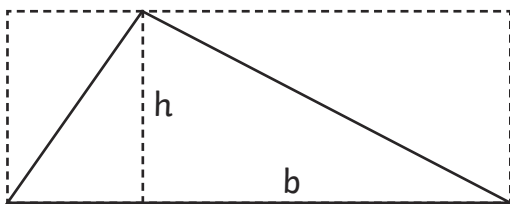

e) The area of a triangle is _____ of the base (b) \times the height (h) or $\frac{1}{2}bh$

A similar idea is used to find the area of a parallelogram. Cut a triangle off one end and move to the other and the parallelogram becomes a rectangle.

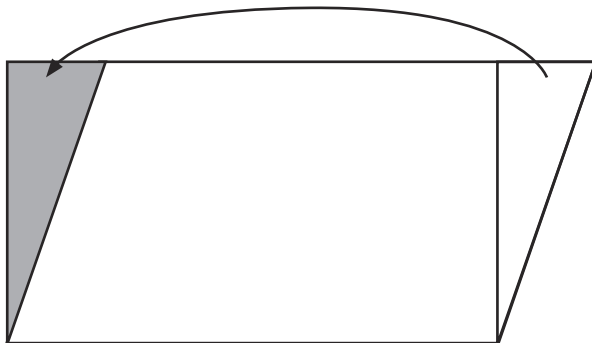

f) The area of a parallelogram is the _____ \times the height (h) or _____.

Money

Add and subtract giving change.

10) Jude buys a bag of apples for £1.25 and a bag of oranges for £2.15. He pays with a £5 note. How much change will he be given?

Time

11a) Match the analogue clock to the digital clock that is showing the same time:

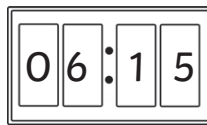
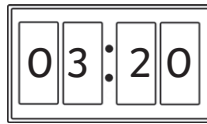
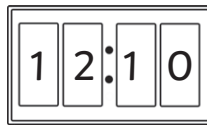
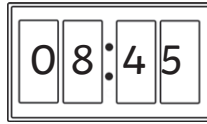
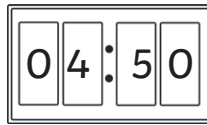

b) A film lasts 136 minutes. How long is the film in hours and minutes?

_____ hours and _____ minutes

c) Convert the following times from 12-hour to 24-hour clock and vice versa:

3:45 p.m. = _____ 11:20 a.m. = _____

15:55 = _____ 06:10 = _____

Solve Problems

12a) 2 equal bottles of water contain 500ml of drink. How many litres will 7 bottles hold?

b) A 6.5kg bag of soil is divided into 20 pots equally. Each pot needs 0.5kg. How much more does each pot need?

_____ ÷ _____ = _____

_____ - _____ = _____ kg is needed by each pot

Geometry – Shape

2D Shapes

1a) Main shapes: circle, triangle, quadrilateral, square, rectangle, rhombus, parallelogram, pentagon, hexagon, octagon, decagon. Identify each one:

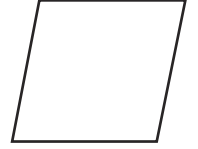
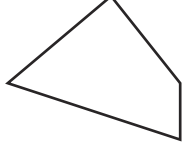
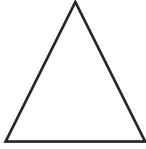
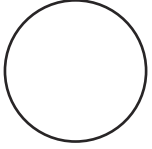

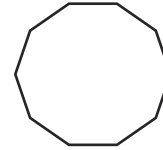
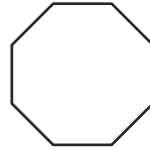
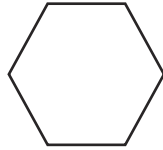
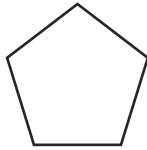

Draw 2D shapes using given dimensions and angles.

b) Draw a square with sides 5cm.

c) Draw an isosceles triangle with one side of 5cm and 2 sides of 7cm.



Compare and classify shapes

2a) Draw the shapes that belong within the venn diagram:

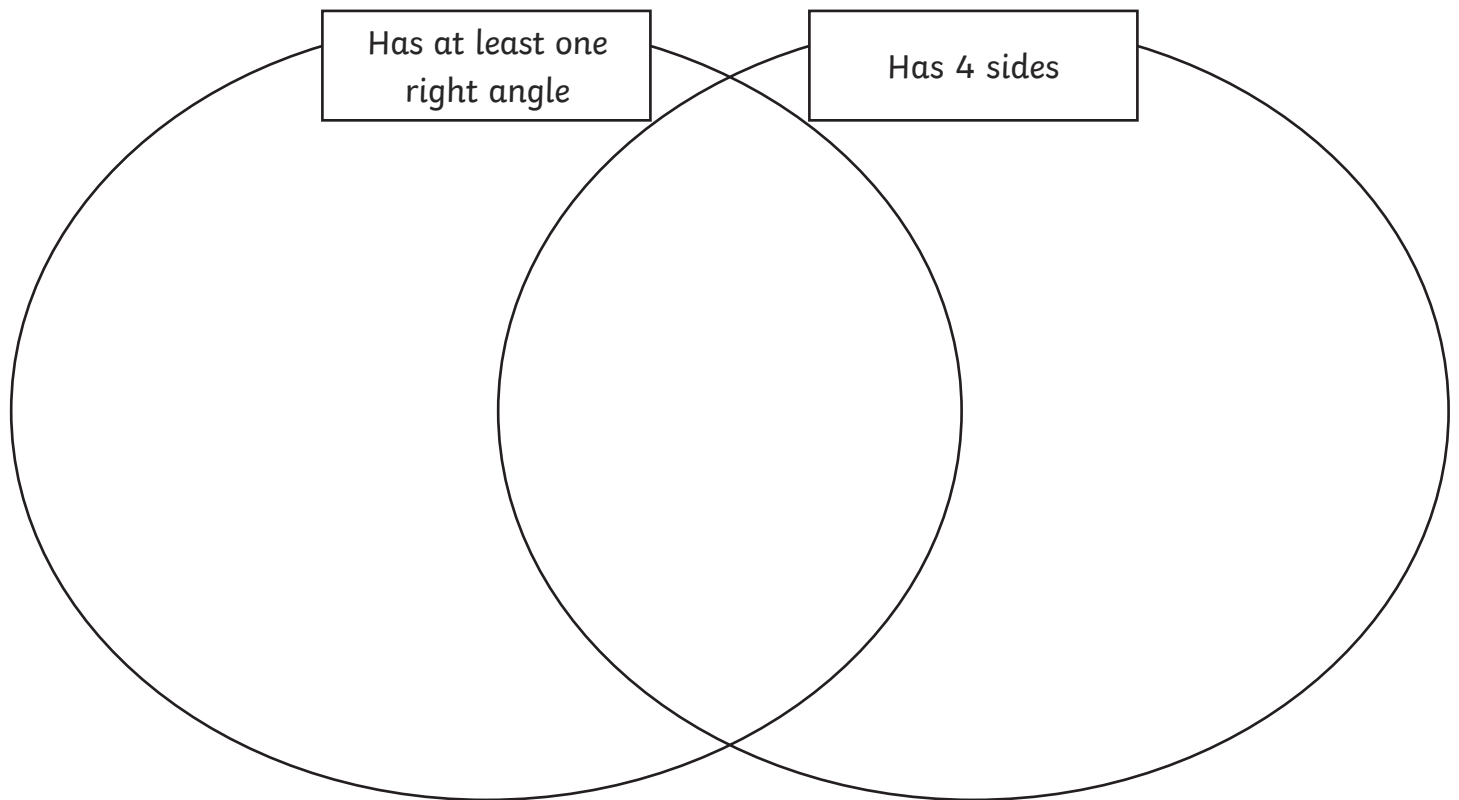
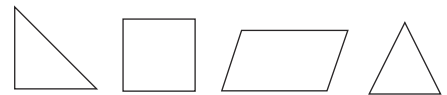

Triangles

Draw a line to the triangle being described:

b) Equilateral (all sides and angles equal)



c) Isosceles (2 sides and angles equal)



d) Scalene (no sides and angles equal)

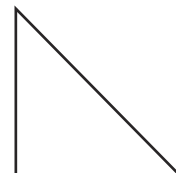

e) Right-angled triangle (one angle a right angle)



3D Shapes

3a) **Main shapes:** sphere, cylinder, cube, cuboid, tetrahedron, square-based pyramid, triangular prism, pentagonal prism, hexagonal prism. Identify each one:

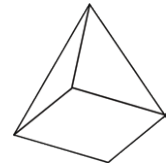
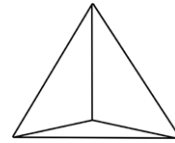
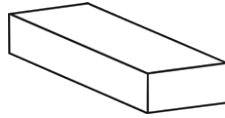
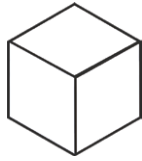
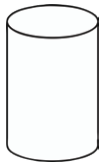
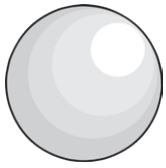

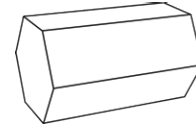
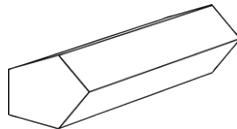
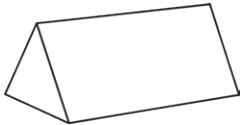

Recognise, describe and build simple 3D shapes, including making nets.

b) What shape is made from this net?

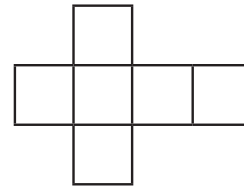

Angles

4a) An angle measures a _____.

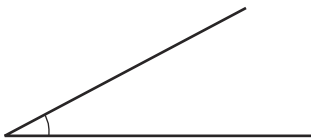

b) A _____ angle is the corner of a square.

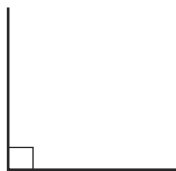

c) 2 right angles make a _____ line.

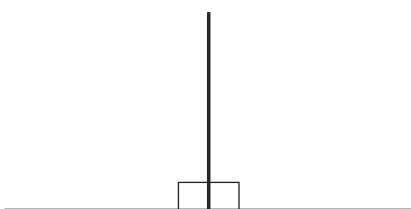

d) An _____ angle is less than a right angle (90°).

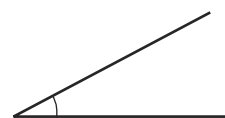

e) An _____ angle is between a right angle and a straight line.

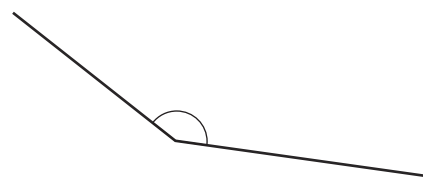

Draw and Measure Angles

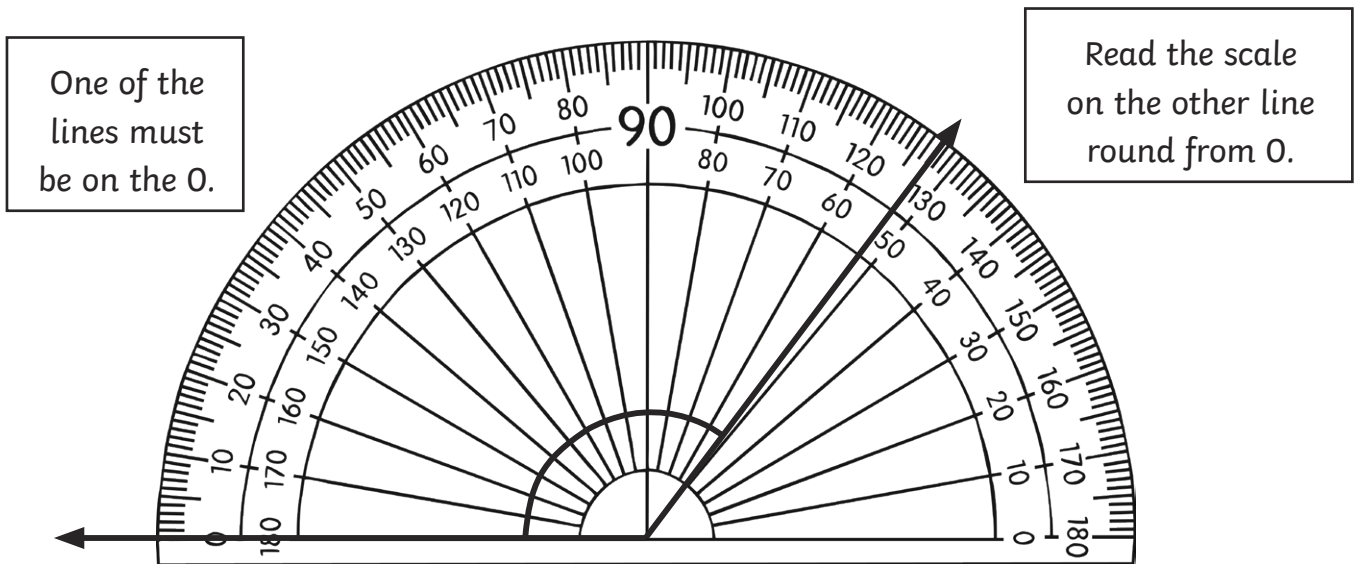

5a) The angle is: _____.

The angles at a point and whole turn total 360° (four right angles).

b) Fill in the missing numbers:

c) Angles at a point on a line total 180° .

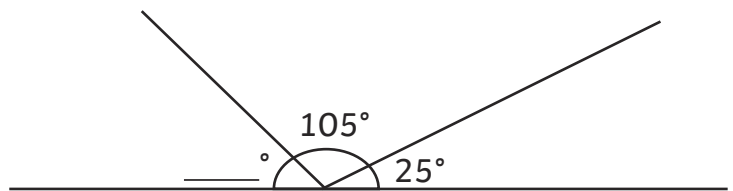
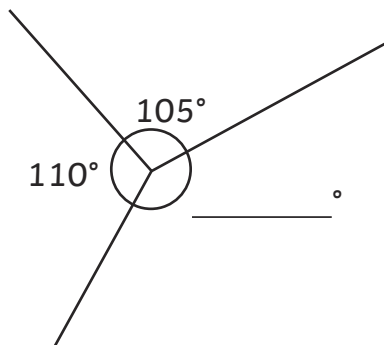

d) One right angle = _____ $^\circ$

e) Two right angles = _____ $^\circ$

f) Three right angles = _____ $^\circ$

Angles in a triangle add up to 180° .

6a) What is the size of angle a? _____.

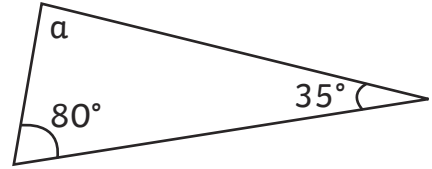

Angles in a quadrilateral add up to 360° .

b) What is the size of angle b, c and d?
_____, _____, _____.

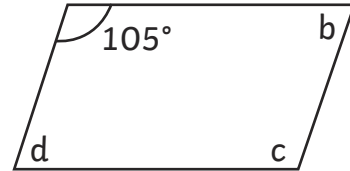

Lines

7) Draw the following lines:

a) Horizontal

b) Vertical

c) Parallel Lines

d) Perpendicular lines (at a right angle)

Symmetry

8) Identify the lines of symmetry with a dotted line:

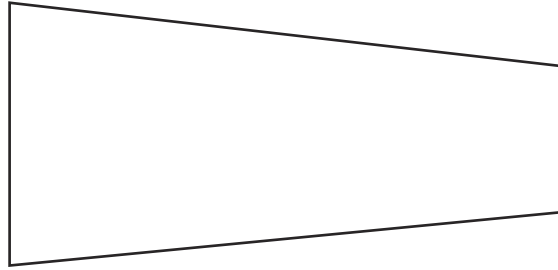
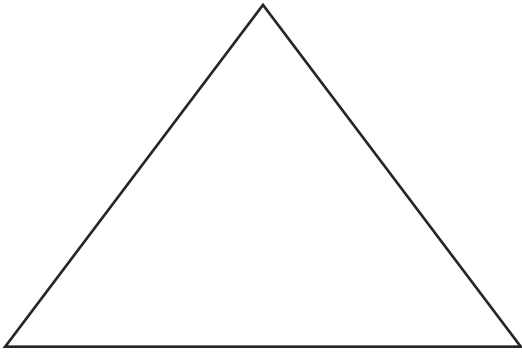

9) Complete two examples of a symmetrical figure:

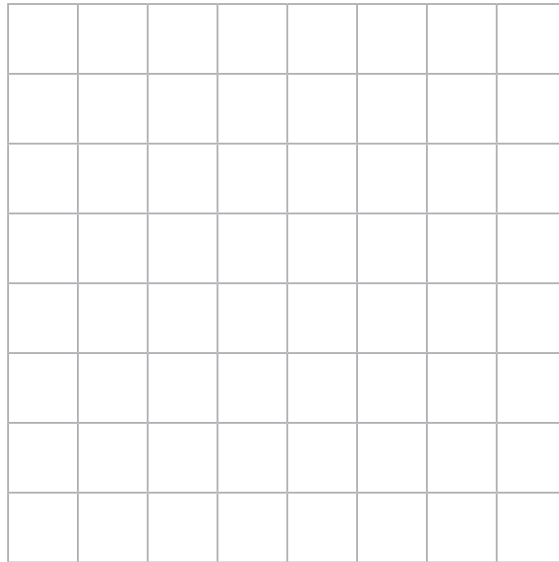
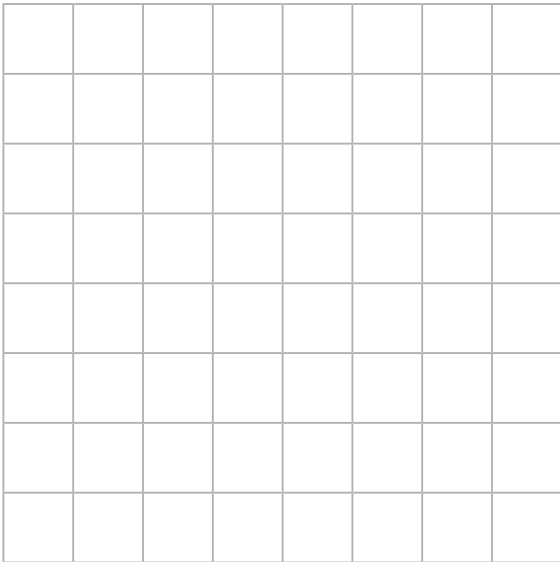

Regular and Irregular Polygons

Regular polygons have equal sides and equal angles.

10a) Identify the following:

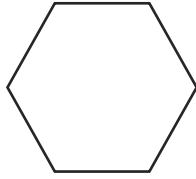
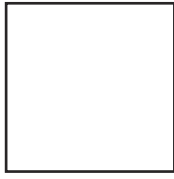

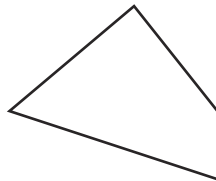
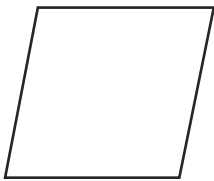

Irregular polygons do not have equal sides and angles. They may have equal angles or equal sides but not both.

A **rhombus** has equal sides and a rectangle has equal angles but they are not regular (unless they are a square).

b) Explain why these shapes are regular polygons.

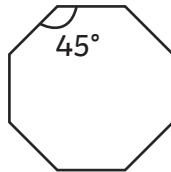
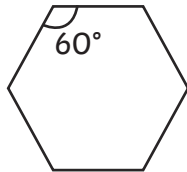
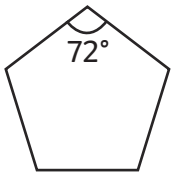

Circles

11a) Identify the main parts of a circle:

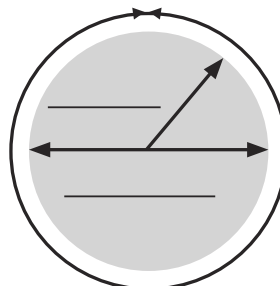

- b) The _____ is the distance around the perimeter of the circle.
- c) The _____ is the distance from the centre to the circumference.
- d) The _____ is the distance from the circumference to the circumference on the other side through the centre of the circle.
- e) The _____ is double the radius.

Geometry – Position and Direction

Coordinates

Coordinates in all four quadrants.

1a) The coordinates are:

A (__, __)

B (__, __)

C (__, __)

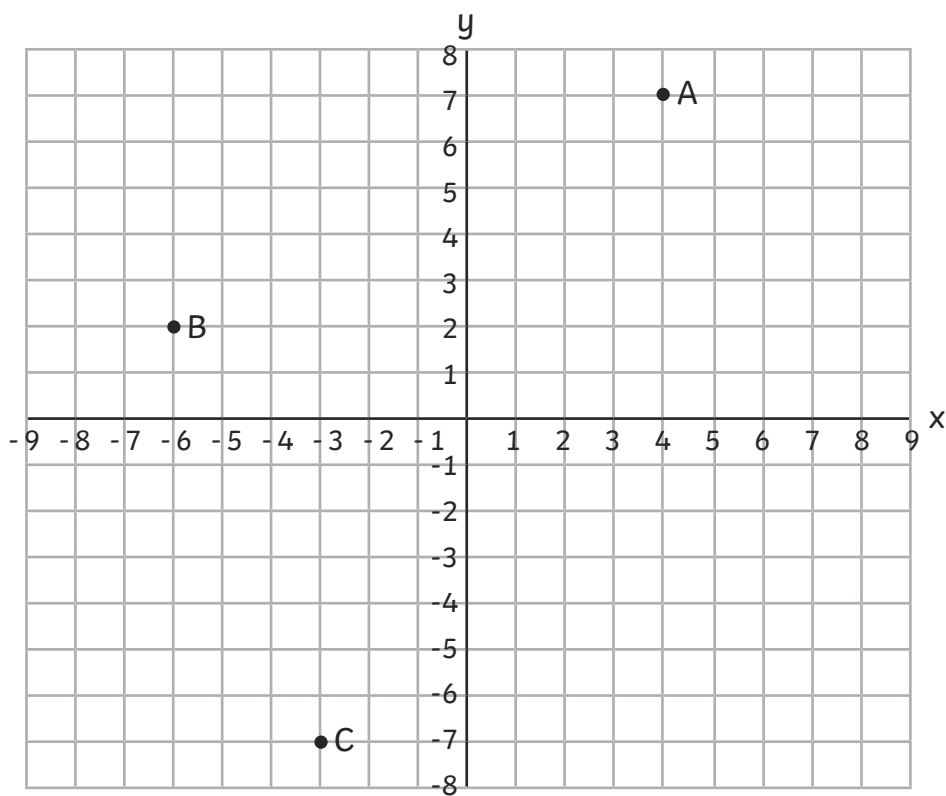

Some coordinates grids are drawn without squares.

b) Work out the coordinates of points a and b.

c) Compare the coordinates of the 2 triangles to find the answer.

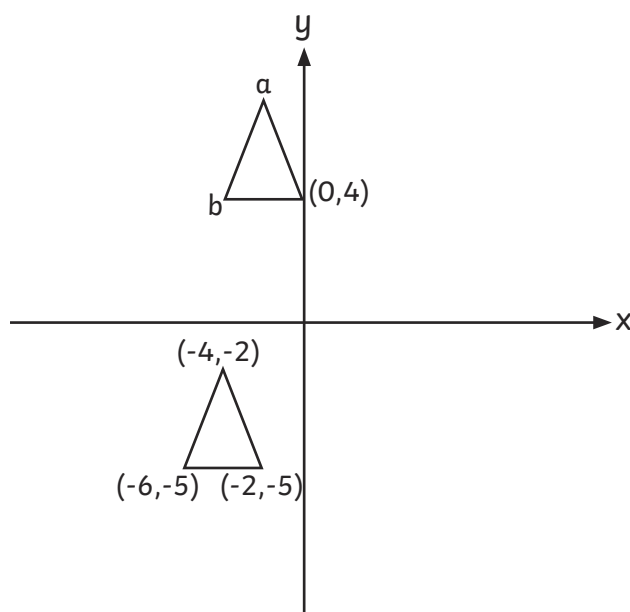

a = (__, __)

b = (__, __)

* not to scale

Translation

Translate shapes on a coordinates grid.

2) Translate this triangle so point A translates to point B.

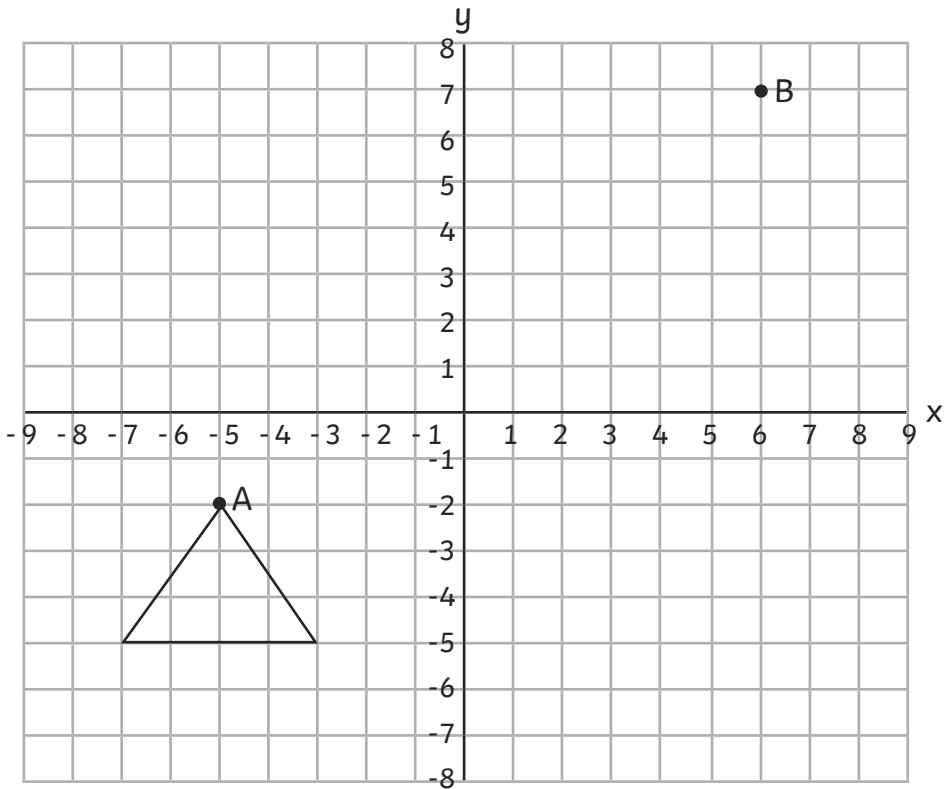

Translations can also be on blank grids as in the coordinates section above.

Reflection

Reflect shapes on a coordinates grid.

3a) Reflect this triangle about the y-axis.

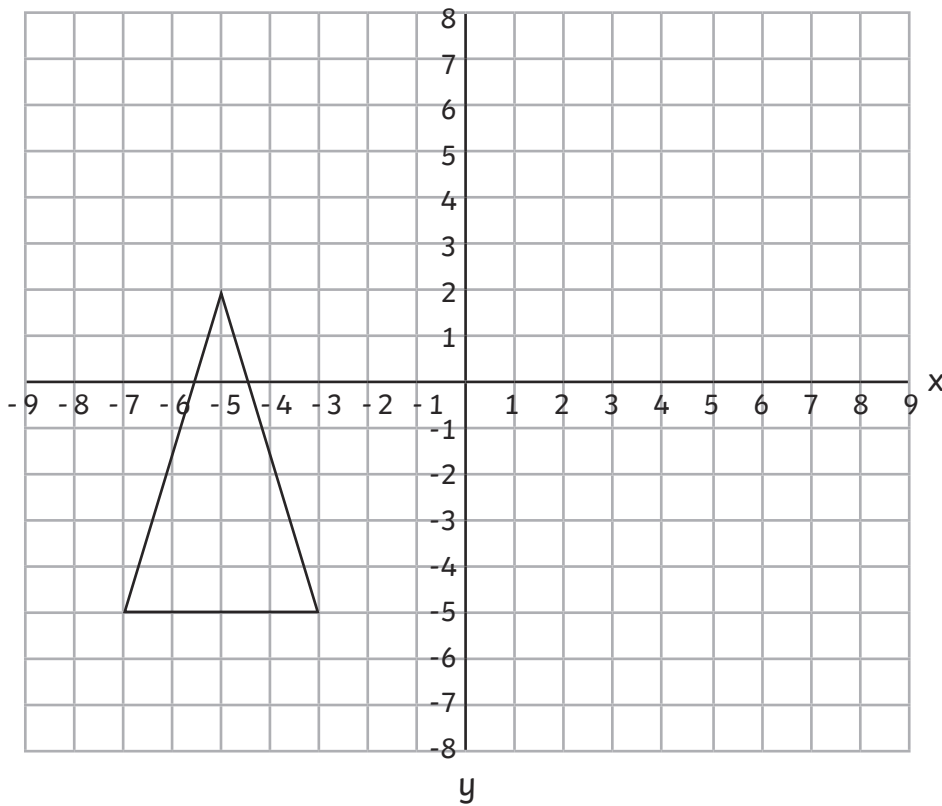

Reflections can also be on blank grids as in the coordinates section above.

Statistics

Present data in these graphs and tables and solve problems:

Pictograms

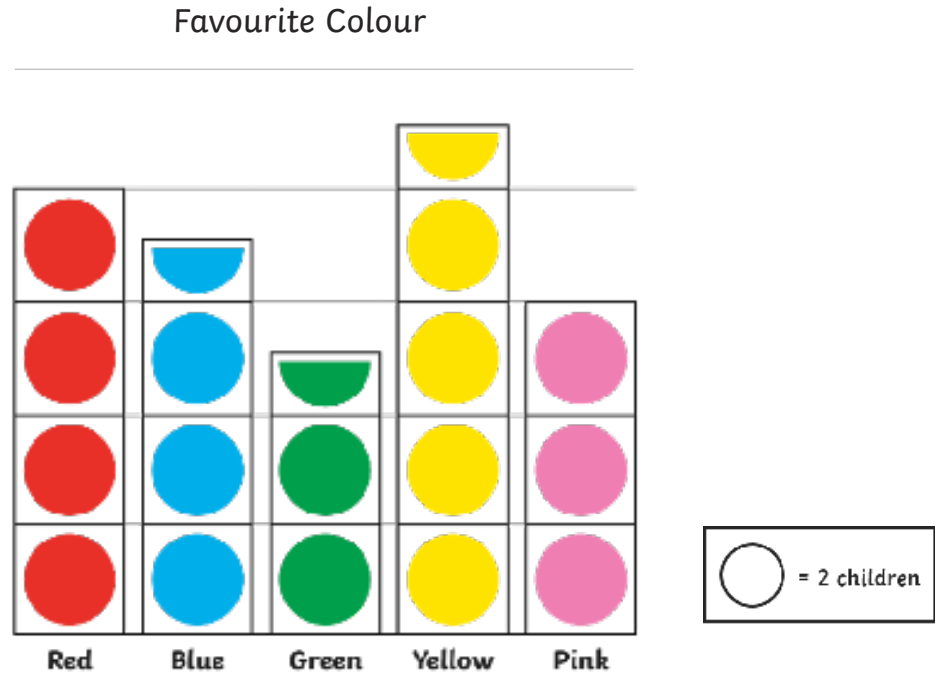

1) How many children were asked to vote for their favourite colour? _____

Bar Charts

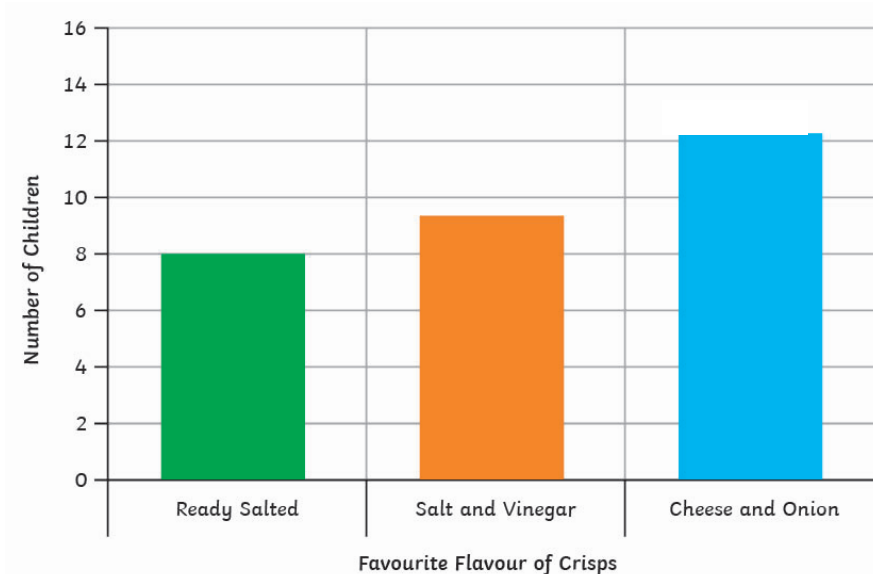

2a) How many more children chose cheese and onion as their favourite crisps than ready salted?

Continuous data can have any value – usually a measurement.

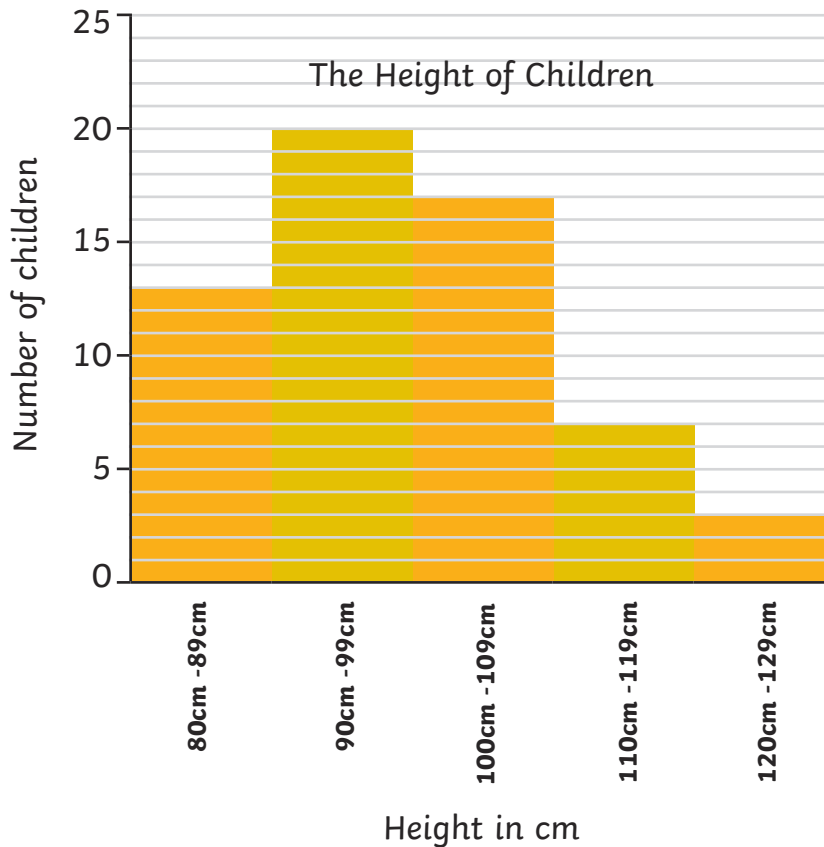

b) How many children are 1m or taller?

Tables

Here is a table showing the number of chocolate bars sold to customers in a shop over 4 days.

	Monday	Tuesday	Wednesday	Thursday
Saturn	2	1	3	4
Twin	0	2	2	3
Stars	5	3	2	0
Cluster	2	2	2	2
Treasure	1	3	5	0
Tiger	6	3	4	1
Plimmy	1	3	2	2

3) Which chocolate bar is the most popular? _____

Time Graphs

Time graphs show the changing of data over time. These often take the form of line graphs but can also be a bar chart.

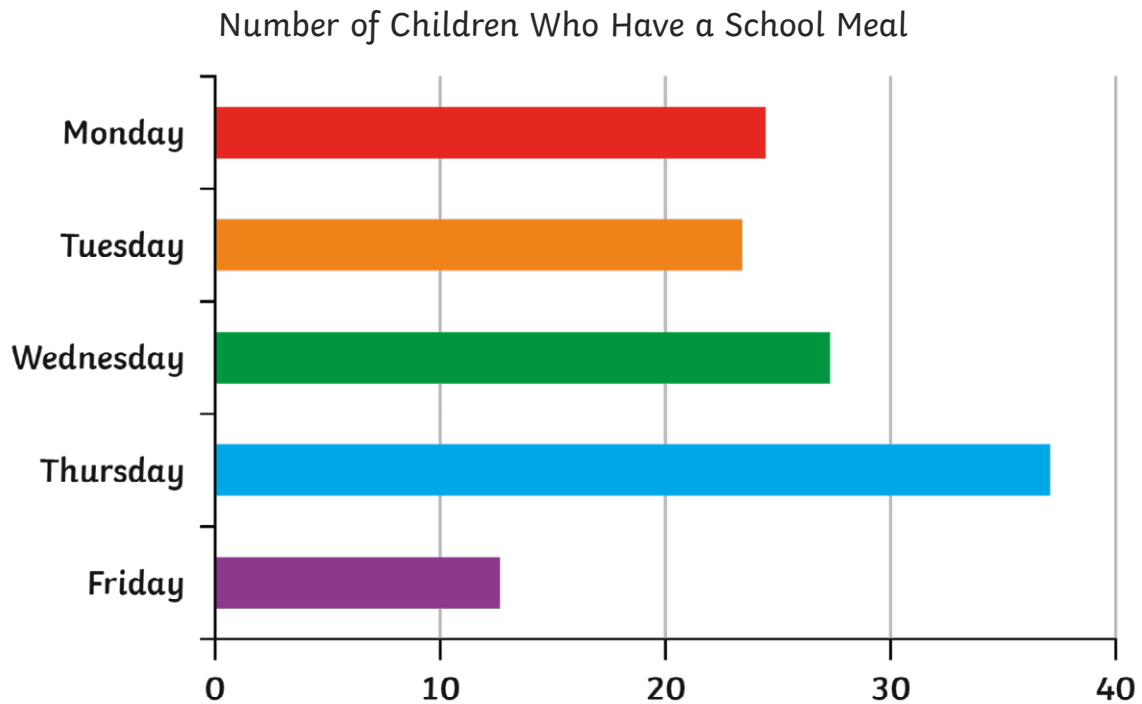

4) How many school meals were served during the week?

Line Graphs

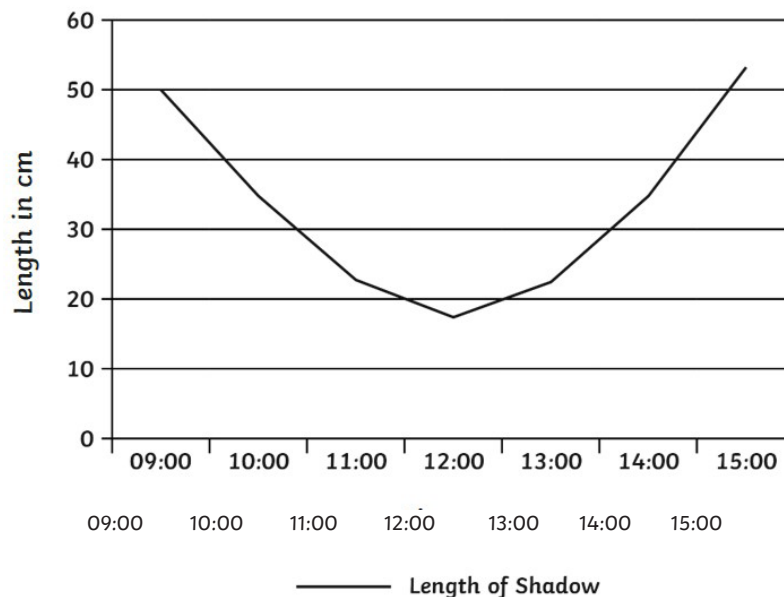

5a) At which time of day was the shadow at its shortest? _____

b) How long was the shadow at 15:00? _____

Timetables

Train timetable from London to Newcastle

Destination	Journey A	Journey B	Journey C
London	10:20	11:30	16:40
Derby	12:20		18:00
Sheffield	12:40	13:10	18:30
Hull	13:20	13:55	19:15
Newcastle	14:25	14:40	

6) Which train takes the least time to get from London to Hull?

Pie Charts

Pie charts show data by dividing a circle to represent the different proportions of the data.

A class of children chose their favourite flavour of crisps. Here is a pie chart of the results.

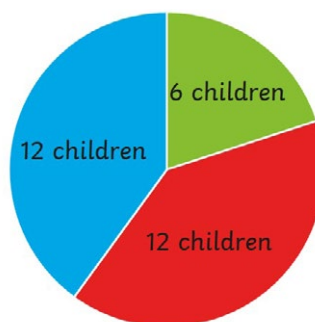
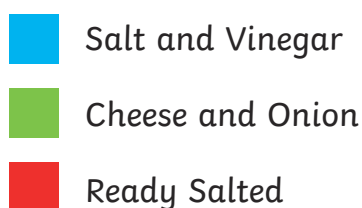

In questions about pie charts children have to use the proportion of the pie to work out answers.

In this pie chart, 20 children are asked how they travel to school.

7) Estimate how many children travelled by bus.

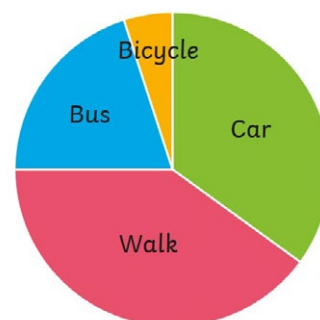

Mean

8a) The mean of a set of data is equivalent to sharing the data out _____.

b) If 4 test scores are 3, 5, 6, 8, the mean is found by adding the data ($3 + 5 + 6 + 8 = \underline{\quad}$) and then sharing between the 4 scores by dividing by 4 ($\underline{\quad} \div 4 = \underline{\quad}$).

c) What is the mean of 15, 17, 20, 24, 24? _____

Important Vocabulary

Some vocabulary is also described within the booklet. Fill in the missing information:

Vocabulary	Meaning
2D shapes	Flat shapes with no thickness. In theory a 2D shape cannot be picked up, but in practice shapes made of paper are counted as 2D. (A list of shapes is included in the section on shape.)
3D shapes	A shape with 3 dimensions that can be picked up. (A list of shapes is included in the section on shape.)
Algebra	
Analogue	
Area	The amount of space taken up by a shape.
	The working out of an answer using addition, subtraction, multiplication or division.
Capacity	
Commutativity	The answer is the same no matter which way the calculation is completed: e.g. $2 + 4 = 4 + 2$ or $2 \times 4 = 4 \times 2$.
	A number that has more than 2 factors. (1 is not a composite number because it only has 1 factor.)
Cube number	The result of multiplying a whole number by itself twice: e.g. $2 \times 2 \times 2 = 8$
Denominator	
	A single symbol used to make a numeral: 7 (All numbers are made from the ten digits 0, 1, 2, 3, 4, 5, 6, 7, 8, 9, 0.)
Digital	A clock using digits to tell the time.
Discrete	
	A statement where the value of each mathematical expression is equal: e.g. $3 + 4 = 7$
Equivalent fraction	A fraction which has the same value but is divided into a different number of parts: e.g. $\frac{1}{2} = \frac{2}{4}$
Factor	A factor of a number is a number into which the number can be divided with no remainders: e.g. the factors of 8 are 1, 2, 4, and 8.
	Factor pairs are 2 factors that are multiplied together to make the number: e.g. the factor pairs of 8 are 1 and 8, 2 and 4.
Fraction	A number expressed as the number of parts into which the whole has been divided: e.g. $\frac{3}{4}$ represents 3 parts out of 4.

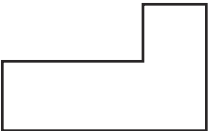
	A fraction where the numerator is larger than the denominator: e.g. $\frac{9}{2}$
	A whole number with no parts: e.g. 5, 18, 109. A whole number with no fraction or decimal part: e.g. 6 or 57.
Inverse	An inverse operation is the opposite or reverse of an operation: e.g. the inverse of $6 - 4 = 2$ is $2 + 4 = 6$ or the inverse of $6 \div 3 = 2$ is $2 \times 3 = 6$. Often known as weight – how much matter is in an object.
Mixed number	A whole number and a proper fraction: e.g. $4\frac{1}{2}$
Numeral	A symbol, symbols, word or words that stand for a number: 37 or thirty-seven.
Numerator	The top part of a fraction.
Perimeter	
Place value	The value of each digit in any number: In 27 the 2 represents 2 tens.
	A 2D shape with any number of sides.
Prime factor	A factor which is a prime number: e.g. 3 is a prime factor of 12.
Prime Number	
Proper fraction	A fraction where the numerator is smaller than the denominator: e.g. $\frac{1}{2}$
	A quarter of the space represented by coordinates, bordered by the x and y axes.
Quadrilateral	Any four sided shape.
Rectilinear	A shape with all angles as right angles (the right angle can be inside or outside the shape). 
Scale	The mathematical relationship between different measurements or number of objects.
Square number	The result of multiplying a whole number by itself: e.g. $2 \times 2 = 4$
	Multiplying 2 numbers by a number and adding, gives the same answer as multiplying the sum of the 2 numbers by the other number: e.g. $4 \times (3 + 2) = 4 \times 3 + 4 \times 2$.
	The movement of a shape without rotation or reflection.
Volume	
	Mass is measured by how much something weighs, but this can change in different locations.